

TECHNICAL CHARACTERISTICS

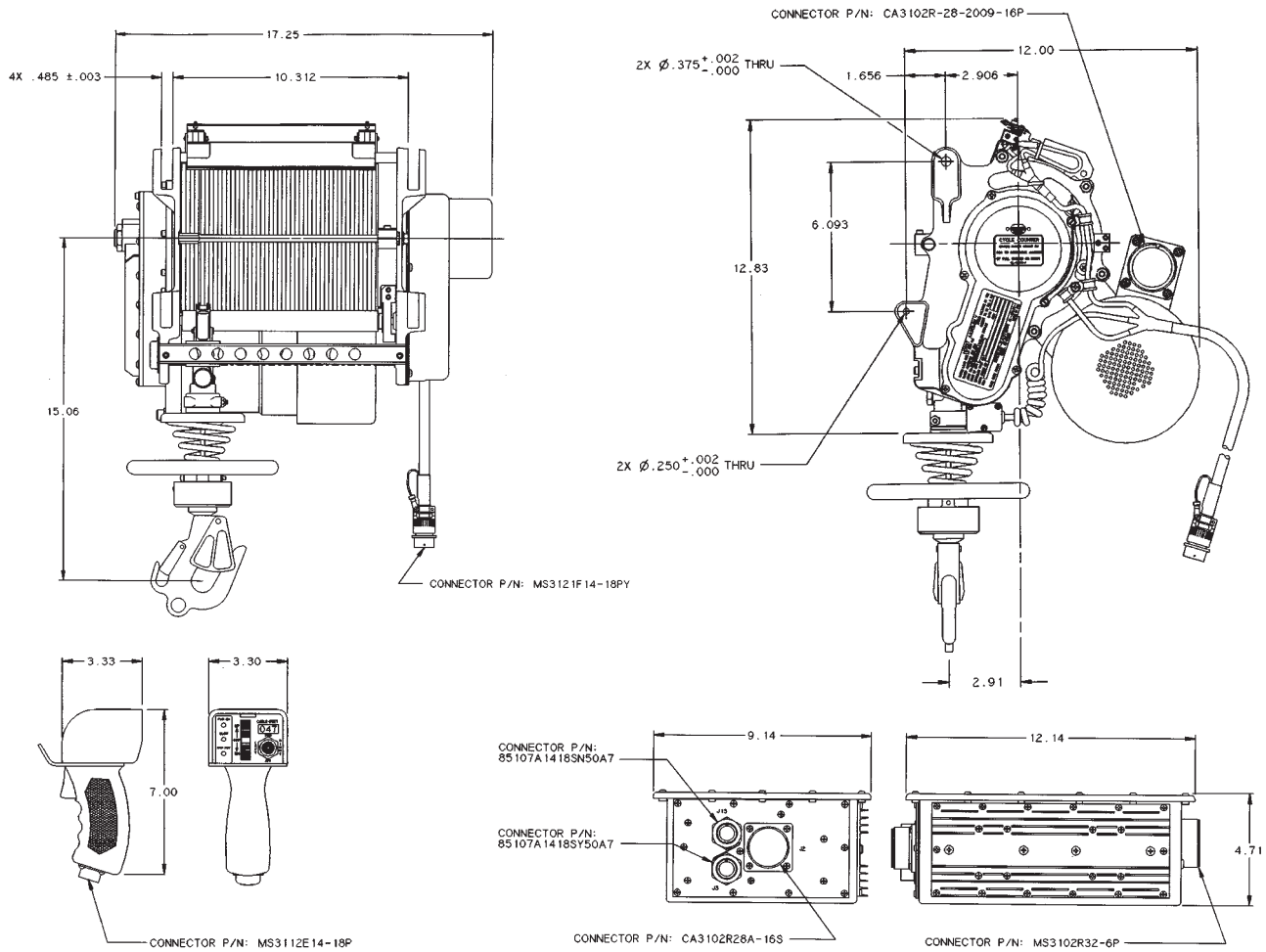

HS-2020 SYSTEM INTERFACES (TYPICAL)

PERFORMANCE (TYPICAL)

Rated load600 lb.....(272 kg)
 Speed @ 600 lb.....0-150 ft/min.....(0-0.76 m/s)
 Speed @ 300 lb.....0-250 ft/min.....(0-1.27 m/s)
 Cable length.....250 ft.....(76 m)
 System weight95 lb.....(43 kg)

POWER REQUIREMENTS (Aircraft Supply)

Voltage.....28 VDC
 Electric current160 A max
 Cable cutter.....28 VDC, 5 A pulse

HOIST CONTROL

Operator.....Up/Down variable speed
 Pilot.....Up/Down fixed speed

DISPLAYS

Digital cable payout
 Power On
 Motor Hot
 Slow Speed
 Cycle counter

SAFETY FEATURES

Electronic overload protection
 Redundant Limit Switches
 Mechanical fail-safe brake
 Cable Foul Sensor
 Safety Clutch
 Cable Tension Control (Bidirectional)

OPTIONAL FEATURES

Various Hook Designs
 Various Control Pendant Designs
 Pilot Cable Payout Display
 Hover Trim 4 Way Switch
 NVG Compatible displays



700 Liberty Avenue, Union NJ 07083-8198 USA
 Telephone (908) 686-4000 • FAX (908) 686-9292
 Product Support Telephone (800) 929-1919
 Web site: www.breeze-eastern.com

ISO 9001, 14001

